

Modular Aluminum Compressed Air Piping INSTALLATION INSTRUCTIONS

If you are experiencing trouble with this product, or missing parts, please call 800-954-3310 for assistance
DO NOT RETURN TO STORE

PLANNING/LAYOUT

Before beginning the installation, create a plan as to the location of the air compressor and where you are going to mount the compressed air outlets. On the plan locate outlets, tees, and elbows.

AIR COMPRESSOR

Use a flexible jumper hose from the air compressor to the filter regulator unit to reduce vibration to the FastPipe System.

FILTER REGULATOR

A filter regulator unit is recommended to keep contaminants out of the air system and to allow for pressure adjustment.

PRESSURE RATINGS

The FastPipe system has a maximum working pressure of 190 psi and a temperature range from 0 to 140°F.



TO AIR COMPRESSOR
Filter Regulator and 3/4" Jumper Hose
Required (Not Included)

ASSEMBLY OF THREADED COMPONENTS

Assemble all NPT threads with two wraps of pipe tape and then PIPE SEALANT which prevents thread galling.

FLAT SURFACE INSTALLATION

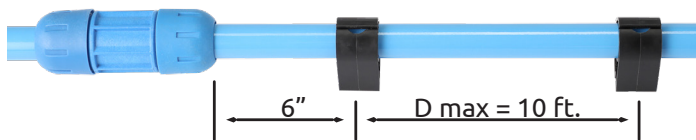

- Hangers or mounting clips should be no more than 10 ft. apart and one must be at least 6" from a fitting

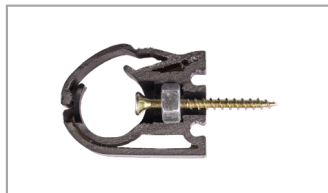

Pipe Clip



Strut Cushion Clamp

- Use pipe clips to secure pipe to any flat surface with mounting screw
- Ceiling or wall mount
- Clip has 5/16" thru hole and hex bore for a 5/16" hex nut
- Hex nut serves as a backer for screws
- Use #10 Drywall Screw or Tapcon
- In horizontal installations, mount clip pivot tab up

HANGING INSTALLATION



- Beam Clamp
- 5/16" Threaded Rod
- Pipe Clip



- Beam Clamp
- 3/8" Threaded Rod
- Pipe Clip

EXPANSION JOINTS



TEMP CHANGE	MAXIMUM STRAIGHT RUN DISTANCE			
	3/4"	1"	1 1/2"	2"
10° F	700 ft.	600 ft.	550 ft.	500 ft.
20° F	500 ft.	460 ft.	420 ft.	370 ft.
35° F	350 ft.	310 ft.	280 ft.	250 ft.
55° F	260 ft.	230 ft.	200 ft.	190 ft.
70° F	200 ft.	190 ft.	170 ft.	150 ft.

Any piping system will expand and contract with temperature changes, use this guide for installation of expansion joints to compensate for this movement of aluminum pipe in non-conditioned buildings

Modular Aluminum Compressed Air Piping

INSTALLATION INSTRUCTIONS

If you are experiencing trouble with this product, or missing parts, please call 800-954-3310 for assistance
DO NOT RETURN TO STORE

INSTALLATION 3/4" - 2"



1
Cut pipe to length with tubing cutter (cut must be square)
DO NOT USE HACK SAW



2
Deburr the end of the pipe outside and inside (a smooth edge allows easy fitting assembly and no damage to the fitting O-ring)



3
Mark end of pipe for the proper insertion depth
 3/4" Fittings: 2 inches
 1" Fittings: 2 - 3/4 inches
 1 1/2" Fittings: 4 inches
 2" Fittings: 4 - 3/4 inches



4
Wet end of pipe with very diluted soapy water
DO NOT USE ANY OIL OR GREASE LUBRICANT



5
Partially loosen fitting cone nut (inner parts, o-ring, stainless steel bite ring)
LOOK INSIDE EACH FITTING FOR INNER PART



6
Insert pipe into fitting until pipe bottoms out
Hand tighten fitting
Fully tighten fitting with FastPipe spanner wrenches

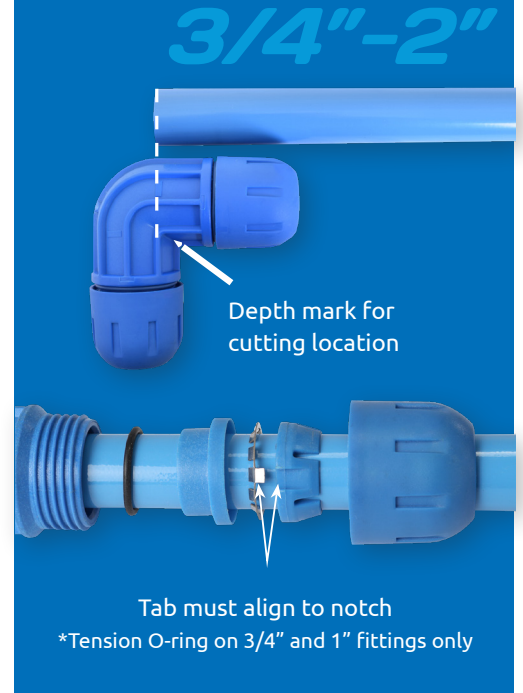

OUTLETS



Wall Outlet
 Outlet ports are 1/2" Female NPT,
 Drain port is 3/8" Female NPT



Wall Outlet With Shutoff



Quick Coupler
 K7241 1/2" Male NPT Thread



Brass Hex Reducing Bushing
 Use a pipe thread bushing 1/2" Male NPT x 1/4" Female NPT to adapt standard 1/4" quick couplers Or use a RapidAir K7241 1/2" Male NPT Quick Coupler

SADDLE DROP INSTALLATION



- Position saddle drop opposite the side of the pipe that needs the hole
Tighten securely and mark the pipe by the raised locating mark on the fitting
Mark the pipe both horizontally & vertically along the fitting edge
- Drill thru one side of the pipe with the drill bit, using the hole in the fitting as a locator
- Insert the saddle drop gasket into the molded cavity
- Position the saddle drop over the drilled hole with aligning marks, tighten securely
- Attach the necessary drop pipe or threaded adapter

- System must be de-pressurized before installing
- To prevent chips from entering the pipe interior, stop drilling occasionally and blow out chips, grease the end of the drilling tool



MAIN SIZE	DRILL BIT	GASKET
1"	9/16" F0043	F2210C
1 1/2"	3/4" F0044	F4210C
2"	3/4" F0044	F5210C

Modular Aluminum Compressed Air Piping

INSTALLATION INSTRUCTIONS

If you are experiencing trouble with this product, or missing parts, please call 800-954-3310 for assistance
DO NOT RETURN TO STORE

WARNINGS

- Compressed air is **DANGEROUS** if not used properly
- Always use **EYE PROTECTION** when using compressed air
- **DO NOT POINT** compressed air at your body or any person
- Pressurize system **SLOWLY**
- **TURN OFF** air compressor when not in use
- **CHECK** local building codes before installation
- **ALWAYS RELIEVE** the system pressure when installing or performing maintenance
- Systems must have a **SAFETY RELIEF** valve installed at the compressed air source to prevent over-pressurization
- **WHEN USING FASTPIPE IN DIRECT SUNLIGHT, COVER OR PAINT THE POLYMER FITTING TO PROTECT IT FROM UV EXPOSURE** (Pipe needs no covering and can be exposed)
- Keep children away from system

FastPipe is not designed:

- For underground burial
- To electrically ground equipment
- To be welded
- To take violent impacts
- To be used where the compressed air treatment is about 140° F
- For environments of caustic or corrosive chemicals



WARNING: This product can expose you to chemicals including lead, which is known to the State of California to cause cancer. For more information, go to www.P65Warnings.ca.gov.

Wash hands after handling.

CONTAINS LEAD: MAY BE HARMFUL IF EATEN OR CHEWED. MAY GENERATE DUST CONTAINING LEAD. KEEP OUT OF THE REACH OF CHILDREN.

3/4"-2"

FASTPIPE INSTALLATION TIPS AND RECOMMENDATIONS:

Care must be taken on any installation of the FastPipe system. Pipes will be carrying compressed air/gas up to 190 psi. The FastPipe system is only as safe as a thorough installation. Read all installation instructions and watch installation videos before starting. Below are some tips for a safe installation.

We strongly recommend that the installer contact our tech department for installation questions PRIOR to the installation.

- Assemble all NPT **PIPE THREADS** with two wraps of Pipe tape and then pipe sealant which prevents thread galling
- Support the pipe with clips / hangers a maximum of **10 FT SPACING** and on **ONE SIDE OF EACH FITTING**
- Any machine/compressor plumbed to the FastPipe must have a **JUMPER HOSE** to reduce vibration
- Any piping system will expand and contract with temperature changes. Use **EXPANSION JOINTS** to compensate for this movement of aluminum pipe in non-conditioned buildings.
- **DO NOT USE** FastPipe for **PULSING** desiccant dryers or other like equipment.
- **CAUTION** installing inert gas bulk tank systems, gas must be warmed up to FastPipe temperature range
- Use a strain relief attached to the building for any rubber hose drops attached to the piping
- **DO NOT** connect quick couplings for air hoses to reducing elbows or tee fittings. The constant connecting/disconnecting and pulling of air hoses could loosen the fitting. Use the FastPipe **WALL OUTLET** which can be secured to a wall or post. Any hoses attached in the ceiling area to a fitting must use a strain relief attached to the building structure
- **CHECK** that all fittings are tightened before pressurizing the system for the first time
- For initial installation, pressurize system **SLOWLY** to 50 psi and check for leaks, then pressurize slowly to MAX 190 psi
- Make sure compressor output temperature does not exceed 140°F.
- **AFTER 24 HOURS** of being pressurized, depressurize the system and **RETIGHTEN** the compression nuts.
- Some settling of components may have occurred. This is not optional, it must be done.
- **FastPipe** can be bent to conform around minor obstacles to a maximum of 15 degrees. **DO NOT OVERBEND.**

PRODUCTS MANUFACTURED BY THE SELLER CARRY A LIMITED ONE YEAR WARRANTY. SEE WWW.RAPIDAIRPRODUCTS.COM FOR MORE DETAILS.

UNION SHOWN AS VISUAL
TOTAL OF 20 PCS/KIT

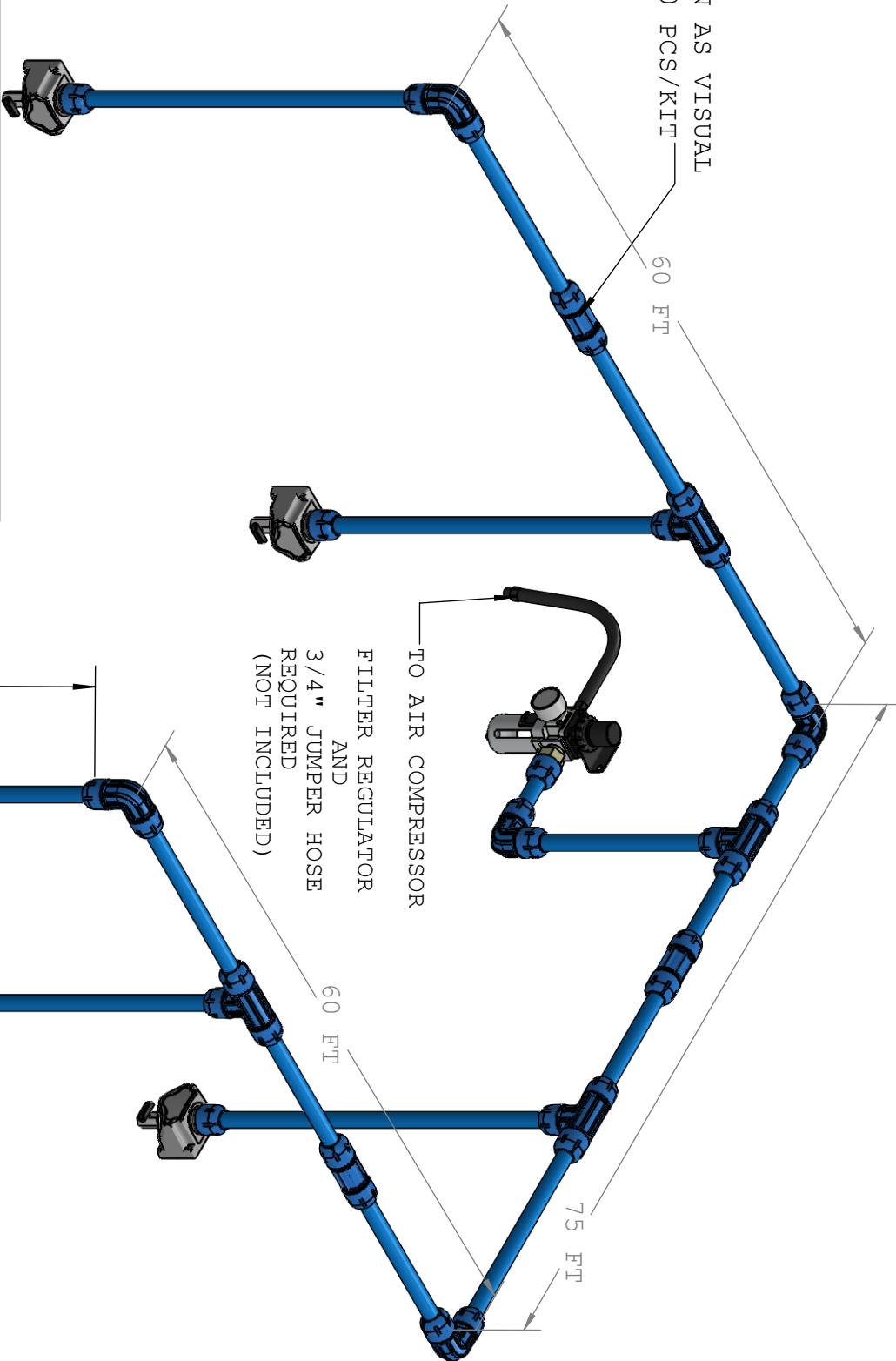

TO AIR COMPRESSOR
FILTER REGULATOR
AND
3/4" JUMPER HOSE
REQUIRED
(NOT INCLUDED)

1" FASTPIPE KIT
#F28240

QTY	PART#	DESCRIPTION
32	F2863	1" PIPE (32 PCS X 7 FT. 6 IN. EACH) 240 FT TOTAL
3	F2022-10	PIPE CLIP (PACK OF 10)
20	F2002	UNION
5	F2003	ELBOW
4	F2005	TEE
1	F2118	THREADED NIPPLE FASTPIPE X 3/4" MALE NPT
5	F2024	WALL OUTLET WITH 1/2" FEMALE NPT OUTLET PORTS
2	F2020	1" SPANNER WRENCH
1	F0142	3/4" - 1" DEBURR TOOL