

PART#	# Ports	INLET	OUTLET	A
H-50-50-4	4	1/2 NPT	1/2 NPT	9.50
H-50-50-5	5	1/2 NPT	1/2 NPT	12.00

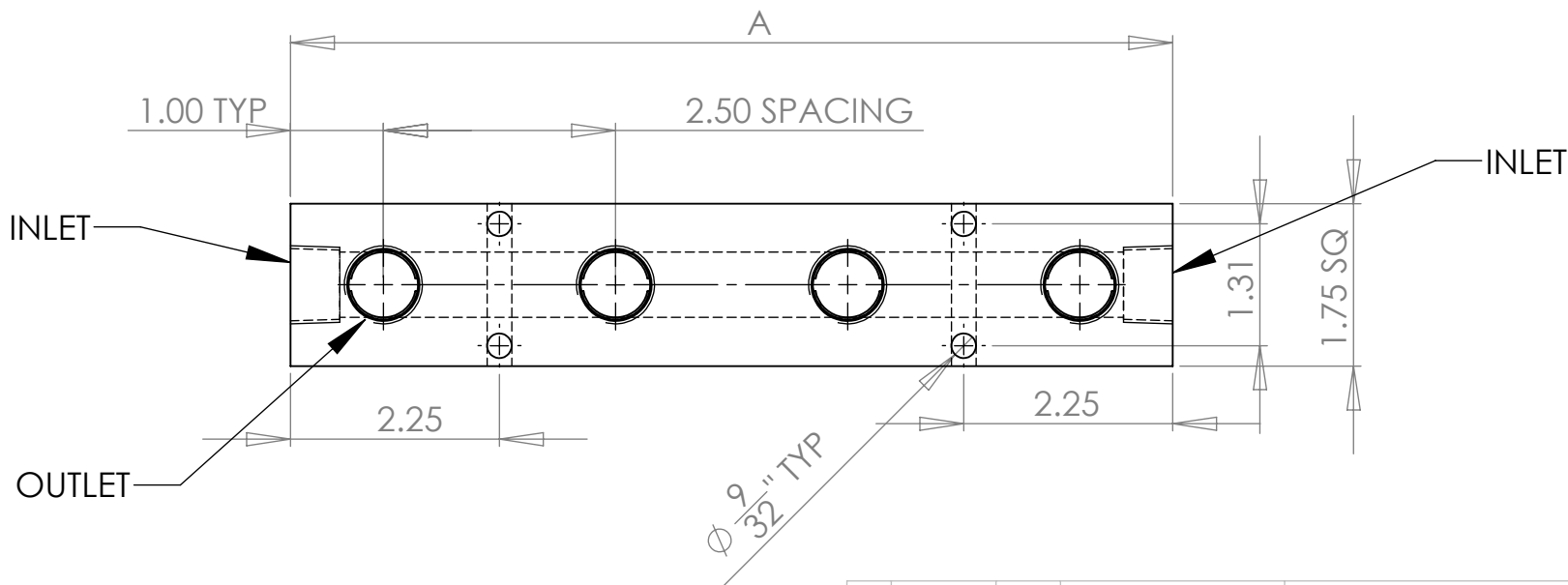
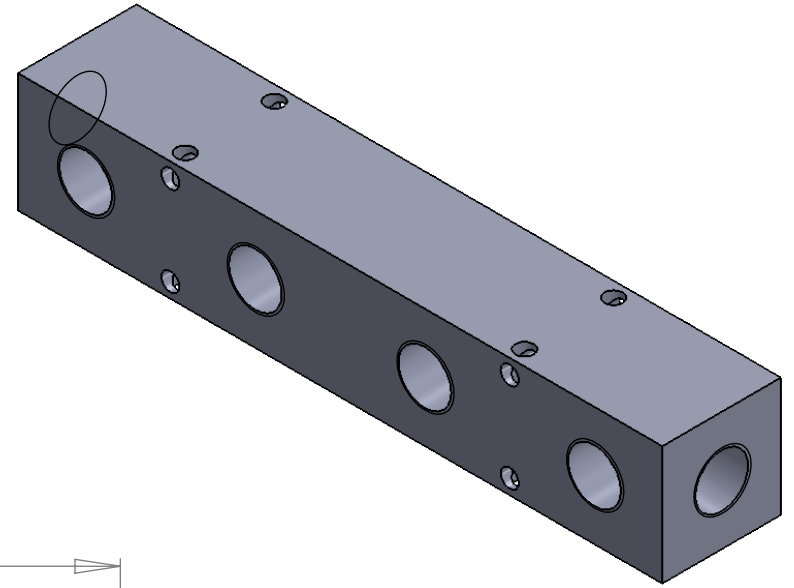

REV #	DATE	BY	DESCRIPTION	ENGINEERED SPECIALTIES, LLC	
				TOLERANCES UNLESS OTHERWISE SPECIFIED FRACTION OF WHOLE ±.030 TWO DIGIT DECIMAL ±.010 THREE DIGIT DECIMAL ±.003 FOUR DIGIT DECIMAL ±.0005 ANGLE ±1°	
				DWG. NAME 1/2" MANIFOLD DWG. NO. H-50-50 MATERIAL 6061 ALUM FINAL FINISH STRAIGHT SAND DRAWN BY CAR DATE 7-15-2014	
1	1-2018	acr	increased spacing		